



Major ratings and characteristics

Parameter	S01DX7012R	Units
$I_{T(RMS)}$	70	A
I_{TSM} @ 50Hz	1200	A
I^2t 5 to 10ms	7200	A ² s
V_{DRM}, V_{RRM}	1200	V
T_J (Operation jct. temperature)	-40 to 125	°C

AC CONTROLLER SUBASSEMBLY

Symbol	Characteristics	Test conditions	S01DX7012R	Units
Voltage ratings				
V_{RRM}	maximum repetitive peak reverse voltage	$T_J = 125^\circ\text{C}$	1200	V
V_{RMS}	maximum non-repetitive peak reverse voltage	$T_J = 125^\circ\text{C}$	1300	V
V_{DRM}	maximum repetitive peak off-state voltage, gate open circuit	$T_J = 125^\circ\text{C}$	1200	V
I_{RRM}, I_{DRM}	Max. peak reverse and off-state leakage current at V_{RRM}, V_{DRM}	$T_J = 125^\circ\text{C}$ $T_J = 25^\circ\text{C}$	20 100	mA μA
On-state Conduction				
$I_{T(RMS)}$	Maximum RMS on-state current	$T_J = 125^\circ\text{C}$	70	A
I_{TSM}	Maximum peak, one cycle non-repetitive on-state current	$t=10\text{ms}$; Initial $T_J = T_{Jmax}$	1050	A
I^2t	Max I^2t for fusing	$t=10\text{ms}$; Initial $T_J = T_{Jmax}$	7200	A ² s
$V_{T(TO)}$	Max value of threshold voltage	$T_J = 125^\circ\text{C}$	0.85	V
V_{TM}	Max peak on-state voltage	$I_{TM} = 150\text{A}$; $T_J = 25^\circ\text{C}$	1.50	V
r_T	Max value of on-state slope resistance	$T_J = 125^\circ\text{C}$	4.6	m Ω
di/dt	Maximum non-repetitive rate of rise of current at turn-on	$T_J=25^\circ\text{C}$ from $0.67V_{DRM}$	150	A/ μs
Triggering				
I_{GT}	Maximum gate current required to trigger	$T_J = 25^\circ\text{C}$	100	mA
V_{GT}	Maximum gate voltage required to trigger	$T_J = 25^\circ\text{C}$	2.50	V
Dynamic Characteristics				
dv/dt	Minimum critical rate of rise of off-state voltage	$T_J = 125^\circ\text{C}$ linear to $0.80V_{DRM}$	500	V/ μs

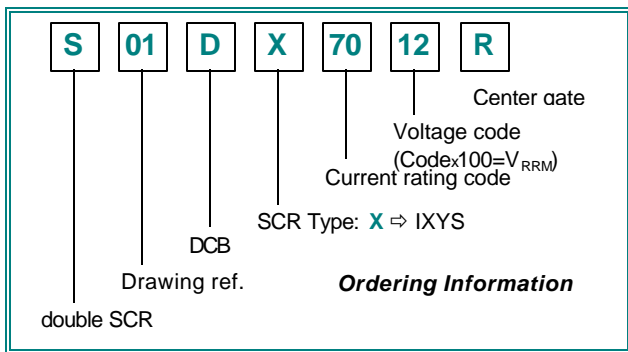
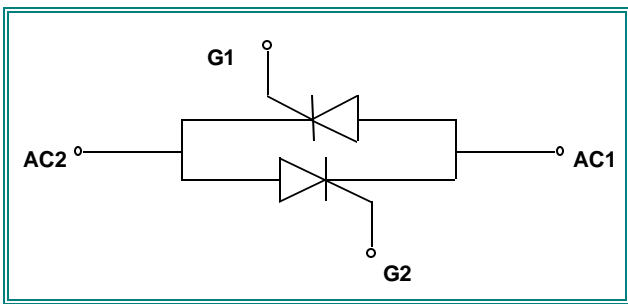

Drawing not in scale - All dimensions in millimeters

