

# MODEL NO. C102A

Specialists In Power Electronic Components And Assemblies

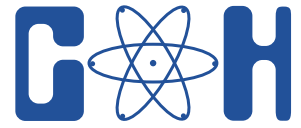

C&H Technology Inc.

**BAR CLAMPS**  
 WITH PRECALIBRATED FORCE  
 BOLT INTERAXYS - 102MM  
 PRESET PRESSURE UP TO 25KN  
 MAXIMUM PUK DIAMETER - 88MM

NOTE: ALL DIMENSIONS ARE IN MM

L	S MIN	S MAX
80	55	70
90	65	80
100	75	90
110	85	100
120	95	110
130	105	120
140	115	130
150	125	140
160	135	150
170	145	160

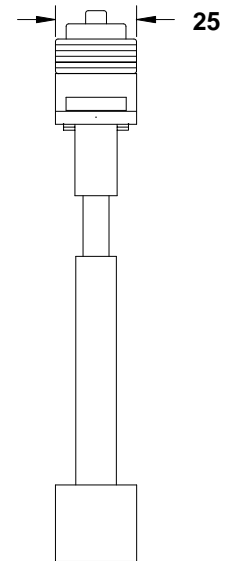
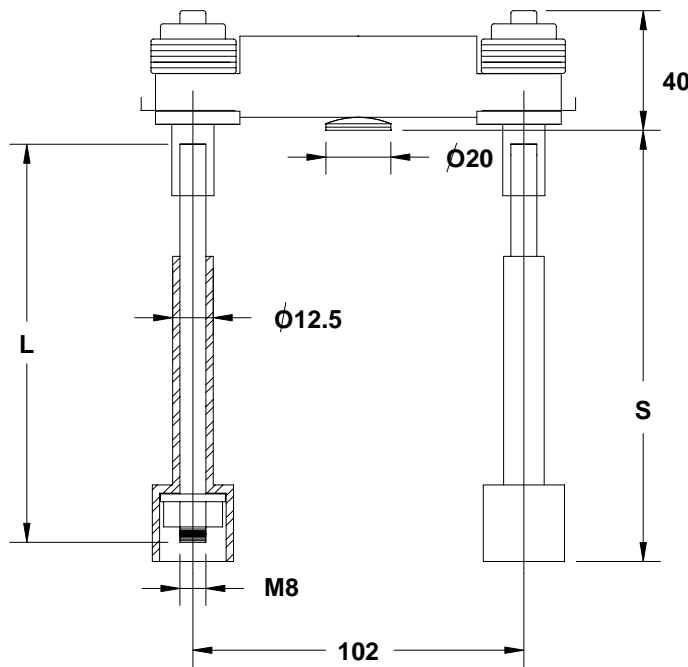
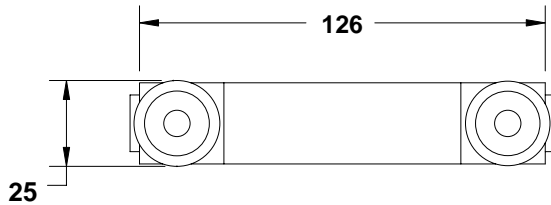

**ORDERING INFORMATION EXAMPLE:**    C102A-22-110

CLAMP MODEL    ↑    ↑    ↑    BOLT LENGTH = 110 MM  
 PRECALIBRATED CLAMPING FORCE = 22 KN    ↑