

STANDARD SIZE BONDED FIN HEAT SINKS

FORCED CONVECTION-SINGLE FAN

Increased thermal performance over natural convection Engineered Heat Sinks. Ideal for applications where high thermal density semiconductors such as IGBT and Power MOSFETs are used. Can be ordered complete with a high performance ball bearing fan installed or fan ready.

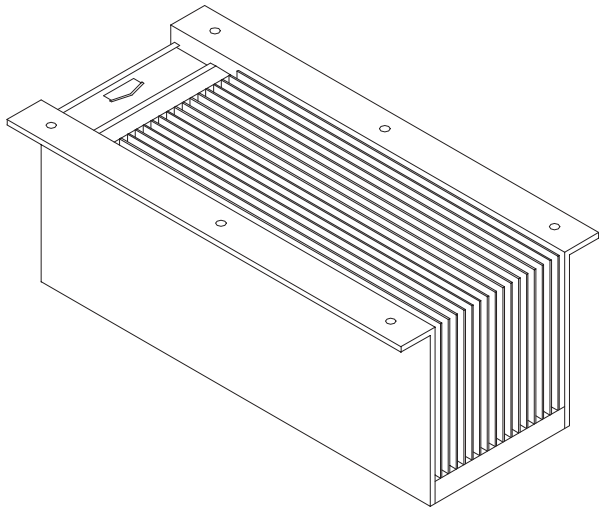
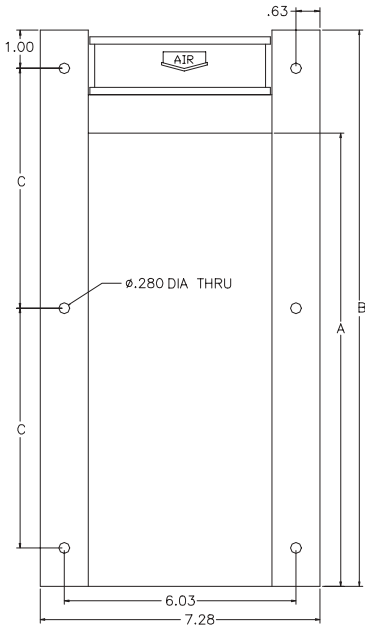
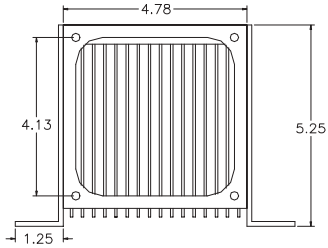

FORCED AIR CONVECTION - SINGLE FAN MODELS

MODEL #	CH5115	CH5116
Dimension A	7.0"	11.81"
Dimension B	9.50"	14.50"
Dimension C	3.75"	6.25"
Thermal Resistance	0.08 °C/W	0.06 °C/W

Thermal performance based on 100 CFM fan(s). Mounting pattern shown fits standard muffin fan(s).