

PHASE CONTROL THYRISTORS

- **Junction Size:** Square 210 mils
- **Wafer Size:** 4"
- **V_{RRM} Class:** 1200 V
- **Passivation Process:** Glassivated MESA
- **Reference IR Packaged Part:** 25RIA Series

Major Ratings and Characteristics

Parameters	Units	Test Conditions
V _{TM} Maximum On-state Voltage	1.5 V	T _J = 25°C, I _T = 25 A
V _{RRM} Reverse Breakdown Voltage	1200 V	T _J = 25°C, I _{RRM} = 100 μA (1)
I _{GT} Max. Required DC Gate Current to Trigger	60 mA	T _J = 25°C, anode supply = 6 V, resistive load
V _{GT} Max. Required DC Gate Voltage to Trigger	1.9 V	T _J = 25°C, anode supply = 6 V, resistive load
I _H Holding Current Range	10 to 125 mA	Anode supply = 6 V, resistive load
I _L Maximum Latching Current	200 mA	Anode supply = 6 V, resistive load

(1) Nitrogen flow on die edge.

Mechanical Characteristics

Nominal Back Metal Composition, Thickness	Cr - Ni - Ag (1 KA - 4 KA - 6 KA)
Nominal Front Metal Composition, Thickness	Cr - Ni - Ag (1 KA - 4 KA - 6 KA)
Chip Dimensions	210 x 210 mils (see drawing)
Wafer Diameter	100 mm, with std. < 100 > flat
Wafer Thickness	370 μm ± 10 μm
Maximum Width of Sawing Line	130 μm
Reject Ink Dot Size	0.25 mm diameter minimum
Ink Dot Location	See drawing
Recommended Storage Environment	Storage in original container, in dessicated nitrogen, with no contamination

Ordering Information Table

Device Code

IR	210	S	G	12	H	CB
①	②	③	④	⑤	⑥	⑦

- 1** - International Rectifier Device
- 2** - Chip Dimension in Mils
- 3** - Type of Device: S = Solderable SCR
- 4** - Passivation Process: G = Glassivated MESA
- 5** - Voltage code: Code x 100 = V_{RRM}
- 6** - Metallization: H = Silver (Anode) - Silver (Cathode)
- 7** - CB = Probed Uncut Die (wafer in box)
None = Probed Die in chip carrier

Outline Table

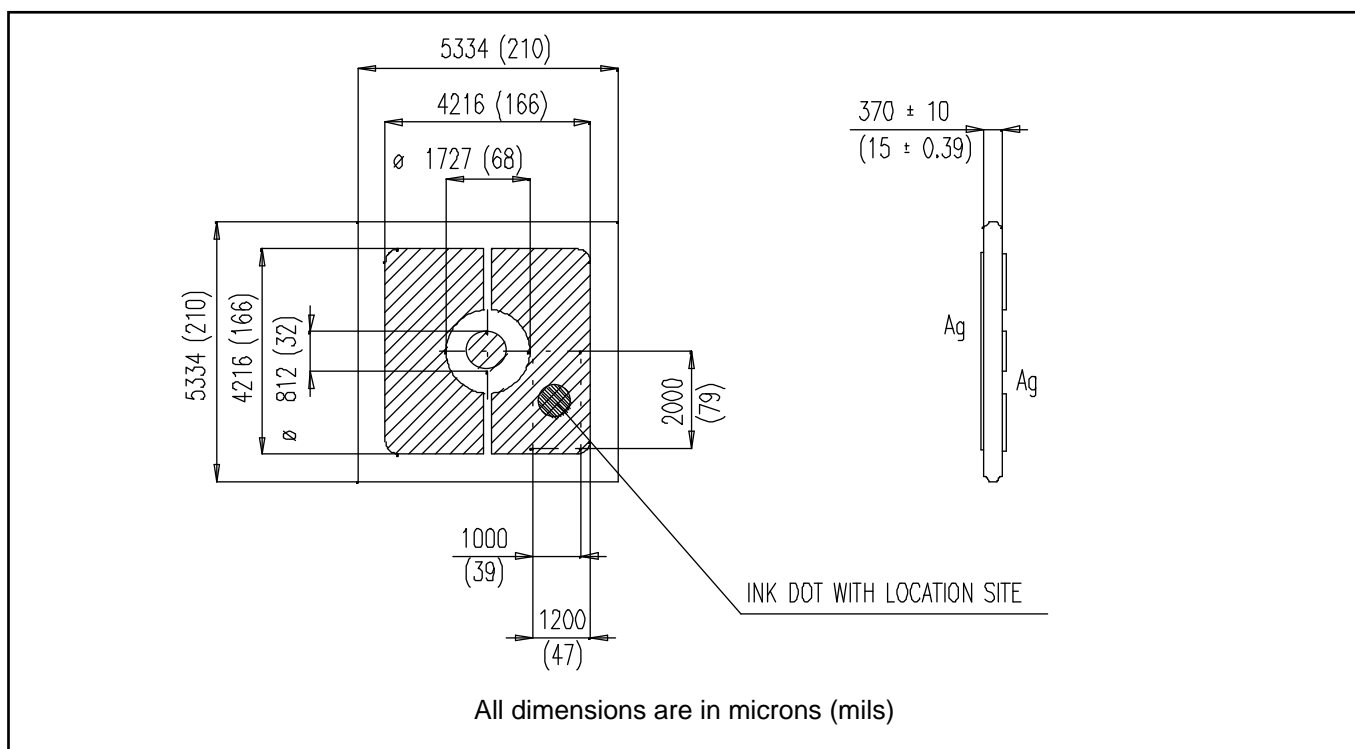

Wafer Layout

